

Partial Discharge Coupling Capacitor 7kV rms / 1000pF



Key Features

- Nominal Voltage 7kVrms
- Build in Quadrupole with voltage reference output
- Build in Overvoltage Protection
- Capacitive floating Signal output to avoid Eddy Current Loops

PDC7-1000

Applications

- Small Hydro Generators
- Windmills
- Industrial Motors

General Description

The 1000pF coupling capacitor is a sensor used for online and offline partial discharge measurements on rotating machines. The sensor will be usually installed at the busbar or on the high voltage terminals of the rotating machine. Permanent or temporary partial discharge detectors / analyzers can be connected via standard RG58 BNC cables to the coupler, usually by using a termination box in between.

The PDC7-1000 has an integrated high voltage cable which will be connected via cable lugs to the high voltage busbars of the rotating machine to pickup partial discharge signals without any loss. A specially designed measurement impedance located in the base of the sensor allows to pickup partial discharge signals as well as the line frequency (1:2000). This allows to transfer partial discharge signals and line frequency signal over the same cable to the partial discharge detector.

The Signal output is protected via 90V surge arrestor. The 'shield' of the coaxial output is capacitive floating to avoid eddy currents in the signal cables due to high magnetic fields.

Ordering Information

Order Code:	18.0070.1000	1x PDC7-1000 Coupling Capacitor
	18.3070.1000.t	3x PDC7-1000, 1x100m Coax Cable, t for Termination box type 6x BNC Crimp on Connectors, Installation Kit
	18.4070.1000.t	4x PDC7-1000, 1x100m Coax Cable, t for Termination box type 8x BNC Crimp on Connectors, Installation Kit
	18.6070.1000.t	6x PDC7-1000, 1x100m Coax Cable, t for Termination box type 12x BNC Crimp on Connectors, Installation Kit

Termination boxes (t):

(00) TB-004 (Standard*), **(1)** TBS-003, **(2)** TBS-004, **(30)** TB-006 (Standard*), **(4)** TB-016, **(x)** custom content

* Variants: **(x1)** 1x CableFeedthrough - 1x Closed, **(x2-x)** 1x FlexTubeKit xm - 1x Closed
(x3-x) 2x FlexTubeKit xm

Flex Tube Kit: 1x M32x1.5 Tube Feedthrough, 1x M25x1.5 Tube Feedthrough, x Meter Flex Tube

Options: /M: with mounting Plate /NCK: Without CoaxialCable and Connectors

Partial Discharge Coupling Capacitor 7kV rms / 1000pF



Technical Data

PDC7-1000

Electrical

Nominal Voltage:	7kV rms	PD Level @ Un:	< 5pC
Capacitance:	1000pF	Voltage Divider:	1:2000
Frequency Range:	50/60Hz	Signal Output Type:	BNC female
		Ground Connection:	M6
Withstand Voltage (1min): (IEC 60071-1)	23kVrms	Creeping Distance (mm):	66+Cable
Lightning Impulse Withstand (BIL): (1.2/50us, 10p / 10n) (IEC 60060-1)	60kVp		

Environment

Operating Temperature Range: -20 .. +125°C

Mechanical

Mounting / Fixing:	4x M6 Allen Key Screws	Electrical Connection:	70cm HV Cable 2.5mm ²
--------------------	------------------------	------------------------	-------------------------------------

Dimensions

Outline:

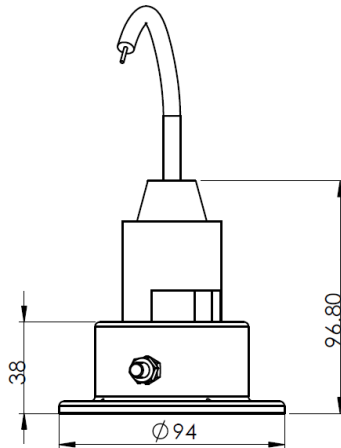

Fixing:

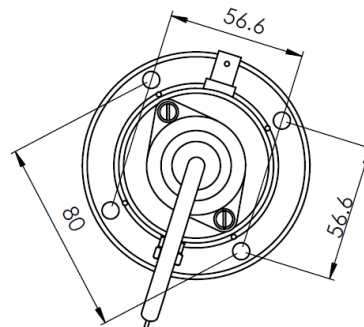

Sparks Instruments reserves the right, without further notice, to change the product specifications and/or the information on this document to improve reliability, functions and design of this product. © 2012, Sparks Instruments SA, All rights reserved.

Contact

Sparks Instruments SA
Route de Montena 85, CH-1728 Rossens
Switzerland

Sales Representative

Phone: +41 (0)26 301 30 04
Email: sales@sparksinstruments.com
Web: www.sparksinstruments.com