



# Fiberoptic Acceleration Sensor

## FAS-110 M5

### FEATURES

- Immunity to magnetic and electrical fields
- Excellent electrical insulation between sensor head - feed-through
- Dual output: acceleration and displacement
- Acceleration output sensitivity: 100mV/g
- Displacement output sensitivity: 10 mV/ $\mu$ m
- Available standard cable length: 10m
- Mode of protection: **Ex mb IIC T4**



### Monitoring solution



Endwinding monitoring

### Typical applications



Hydrogenerators



Gearless millsdrives



Turbogenerators

### DESCRIPTION

The FAS Fiberoptic Acceleration Sensor is designed to be non conductive and immune to electro-magnetic interferences. Its optical link ensures an excellent electrical insulation between the sensor and the instrumentation.

Its passive technology makes it ideal for shock and vibration measurements in areas where conventional piezo-electric and piezoresistive accelerometers may create hazards to machine and personnel and impair reliable operation.

The optical sensor body does not contain any metallic parts. The optical fibers are embedded and protected by an integral 5mm thick PTFE tube. The standard available optical cable lengths is 10m. The sealed feedthrough connector houses the optoelectronic and conditioning circuitry.

The sensor provides dual output, acceleration and displacement, simultaneously.

## GLOBAL SPECIFICATIONS

---

### OPERATION

Outputs	Acceleration	Displacement
Sensitivity at 100Hz	100mV/g $\pm$ 5%	10mV/ $\mu$ m $\pm$ 5%
Bias voltage	+6V <sub>DC</sub>	+7.5V <sub>DC</sub>
Frequency response (-3dB)	10 to 400Hz	20 to 400Hz
Output resistance	100 $\Omega$ $\pm$ 1%	
Measuring range	0 to 40g (1mm peak-peak at 100Hz)	
Resonance frequency	>600Hz	
Transverse sensitivity	< 5% with respect to sensitive axis	
Residual noise	< 3mV <sub>rms</sub> overall noise between 20 and 400Hz	
Resolution	< 1 $\mu$ m peak-peak at 100Hz	
Power supply		
Voltage	+24V <sub>DC</sub> $\pm$ 20%	
Current consumption	< 30mA	

---

### ENVIRONMENTAL

Temperature range - part :	Sensor	Electronic
Operation	+20° to +155°C	0° to 70°C
Non-destructive	-20° to 155°C	-20° to 85°C
Resistance against surge voltage	5MV/m	
Resistance against withstand voltage	65kV for 1 minute (50/60Hz)	
Operating Pressure	500 kPa hydrogen (sensor head only)	
Max. Shock Acceleration	600g half sine, duration 1ms	
Magnetic Field	Max 1 Tesla RMS at 50(60)Hz	
Electrical Field	Max 5 MV/m RMS at 50(60)Hz	
CE certification	In conformance with EN 61000-6-2 and EN 61000-6-3	
<b>Ex mode of protection</b>	<b>Ex mb IIC T4</b>	

---

### PHYSICAL

Sensor head dimensions [mm]	35 x 18 x 18 LxWxH
Sensor head weight [g]	30
Sealed feed-through dimensions [mm]	75 L x $\varnothing$ 30 ; Thread: 45 L x M18x1
Sealed feed-through weight [g]	130
Recommended max. tightening torque	20 Nm
Integral cable dimensions	10m x $\varnothing$ 5mm ; minimum bending: 80mm radius
Extension cable information	10m length cable (other length on request) terminated by a 4 pins connector embedded in stainless steel case, not removable in normal operation. Other end blunt cut. Optionally with flexible stainless steel armor

---

**ORDERING INFORMATION**

Part type           Fiberoptic acceleration sensor  
 Ordering code    02.110.000 M5  
 Description       FAS-110 M5

Sensor head composed of polymer & ceramic, mounted on 2 fibre glass strands with PTFE protection tubing of 10m, terminated by a stainless steel sealed feed-through with a M12 4-pin connector. Delivered with Viton O-ring 22x2.5mm and 2 hex nuts M18 x 1

Other available length (on request)

Ordering code	02.106.000 M5	02.115.000 M5
Description	FAS-106 M5	FAS-115 M5
	6m length	15m length

**AVAILABLE ACCESSORIES**

Part type           Extension cable, 10m length without armor 4x0.34mm<sup>2</sup>  
 Ordering code    02.904.010  
 Part type           Extension cable, 10m length armored 4x0.34mm<sup>2</sup>  
 Ordering code    02.903.010

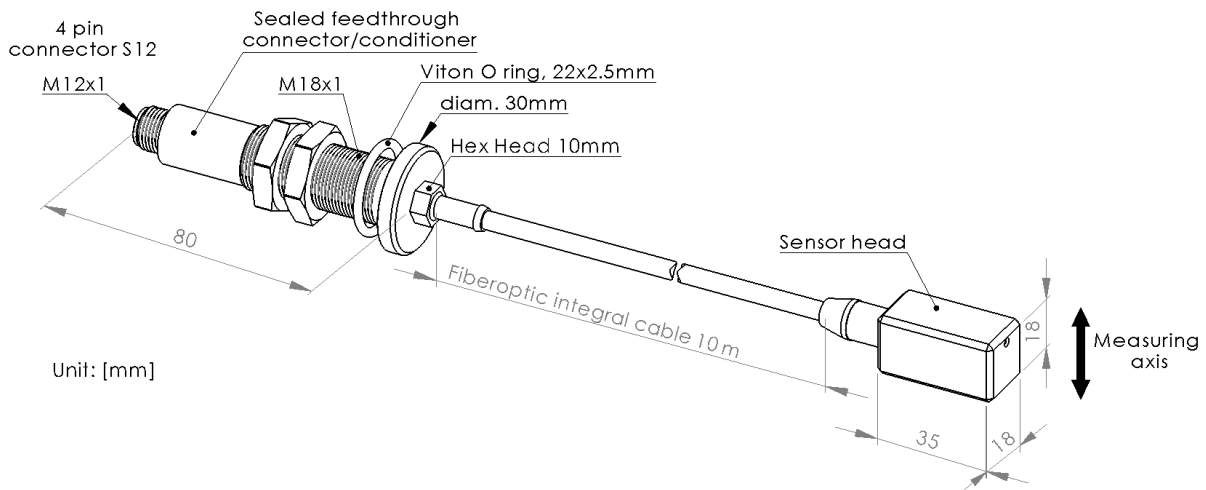
**MECHANICAL DRAWING**

MC-monitoring Quality certifications



LOCAL REPRESENTATIVE

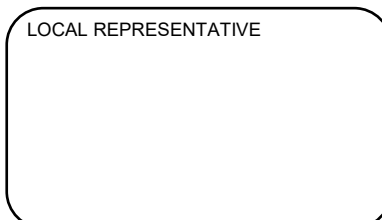

MC-monitoring SA  
 Route André Piller 19 | PO BOX 97  
 CH-1762 Givisiez | Switzerland  
 Phone : +41 58 411 54 00  
 Fax : +41 58 411 54 10  
 Mail : info@mc-monitoring.com  
       sales@mc-monitoring.com  
 Web : [mc-monitoring.com](http://mc-monitoring.com)