



Fiberoptic Acceleration Sensor

FAS-110 M2

FEATURES

- Immunity to magnetic and electrical fields
- Excellent electrical insulation between sensor head - feed-through
- Dual output: acceleration and displacement
- Acceleration output sensitivity: 100mV/g
- Displacement output sensitivity: 10 mV/ μ m
- Available standard cable length: 10m
- Dual axis available with special assembly of two sensors



Monitoring solution



Endwinding monitoring

Typical applications



Hydrogenerators



Gearless millsdrives



Turbogenerators

DESCRIPTION

The FAS Fiberoptic Acceleration Sensor is designed to be non conductive and immune to electromagnetic interferences. Its optical link ensures an excellent electrical insulation between the sensor and the instrumentation.

Its passive technology makes it ideal for shock and vibration measurements in areas where conventional piezo-electric and piezoresistive accelerometers may create hazards to machine and personnel and impair reliable operation.

The optical sensor body does not contain any metallic parts. The optical fibers are embedded and protected by an integral 5mm thick PTFE tube. The standard available optical cable lengths is 10m. The sealed feedthrough connector houses the optoelectronic and conditioning circuitry.

The sensor provides dual output, acceleration and displacement, simultaneously.

GLOBAL SPECIFICATIONS

OPERATION

Outputs	Acceleration	Displacement
Sensitivity at 100Hz	100mV/g \pm 5%	10mV/ μ m \pm 5%
Bias voltage	+6V _{DC}	+7.5V _{DC}
Frequency response (-3dB)	10 to 400Hz	20 to 400Hz
Output resistance	100 Ω \pm 1%	
Measuring range	0 to 40g (1mm peak-peak at 100Hz)	
Resonance frequency	>600Hz	
Transverse sensitivity	< 5% with respect to sensitive axis	
Residual noise	< 3mV _{rms} overall noise between 20 and 400Hz	
Resolution	< 1 μ m peak-peak at 100Hz	
Power supply		
Voltage	+24V _{DC} \pm 20%	
Current consumption	< 30mA	

ENVIRONMENTAL

Temperature range - part :	Sensor	Electronic
Operation	+20° to +155°C	0° to 70°C
Non-destructive	-20° to 155°C	-20° to 85°C
Resistance against surge voltage	5MV/m	
Resistance against withstand voltage	65kV for 1 minute (50/60Hz)	
Operating Pressure	500 kPa hydrogen (sensor head only)	
Max. Shock Acceleration	600g half sine, duration 1ms	
Magnetic Field	Max 1 Tesla RMS at 50(60)Hz	
Electrical Field	Max 5 MV/m RMS at 50(60)Hz	
CE certification	In conformance with EN 61000-6-2 and EN 61000-6-3	

PHYSICAL

Sensor head dimensions [mm]	35 x 18 x 18 LxWxH
Sensor head weight [g]	30
Sealed feed-through dimensions [mm]	75 L x \varnothing 30 ; Thread: 45 L x M18x1
Sealed feed-through weight [g]	130
Recommended max. tightening torque	20 Nm
Integral cable dimensions	10m x \varnothing 5mm ; minimum bending: 80mm radius

ORDERING INFORMATION

Part type Fiberoptic acceleration sensor
Ordering code 02.110.000 M2
Description FAS-110 M2

Sensor head composed of polymer & ceramic, mounted on 2 fibre glass strands with PTFE protection tubing of 10m, terminated by a stainless steel sealed feed-through with a M12 4-pin connector. Delivered with Viton O-ring 22x2.5mm and 2 hex nuts M18 x 1

Other available length (on request)

Ordering code	02.106.000 M2	02.115.000 M2
Description	FAS-106 M2	FAS-115 M2
	6m length	15m length

AVAILABLE ACCESSORIES

Part type Extension cable, 10m length without armor 4x0.34mm²
Ordering code 02.902.010
Other length on request

MECHANICAL DRAWING

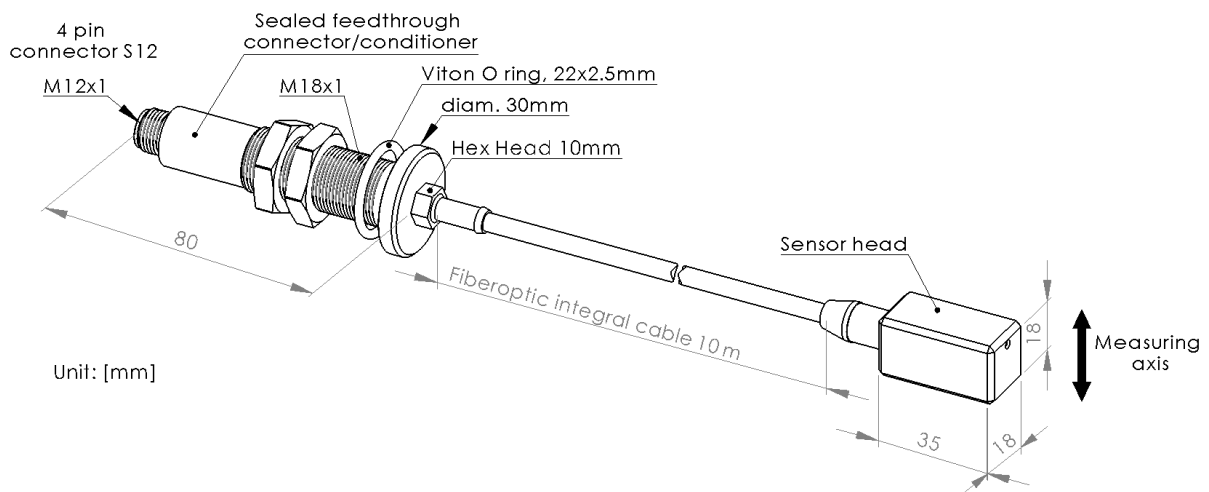

MC-monitoring Quality certifications



LOCAL REPRESENTATIVE

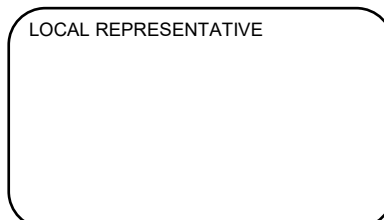

MC-monitoring SA
Route André Piller 19 | PO BOX 97
CH-1762 Givisiez | Switzerland
Phone : +41 58 411 54 00
Fax : +41 58 411 54 10
Mail : info@mc-monitoring.com
sales@mc-monitoring.com
Web : mc-monitoring.com